

GP2D12/15 Application Note

Opto-Electronic Devices Div.  
ELECOM Group  
SHARP CORPORATION

## 1. General Description

This GP2D12/15 application note has been completed by preparing several characteristic data for customers' convenient reference when the GP2D12/15 are used. Please utilize this application note for customers' design. This application note should be for reference, however please make sure them in actual mounted condition before using.

## 2. Measuring principal and features of this sensor

### 2-1. Principal of triangulation

Optical spot position on PSD shall be changed when reflective object is at "A" point and at "B" point. By processing this optical spot position electrically, the position (distance) of the reflective object on straight line can be detected.

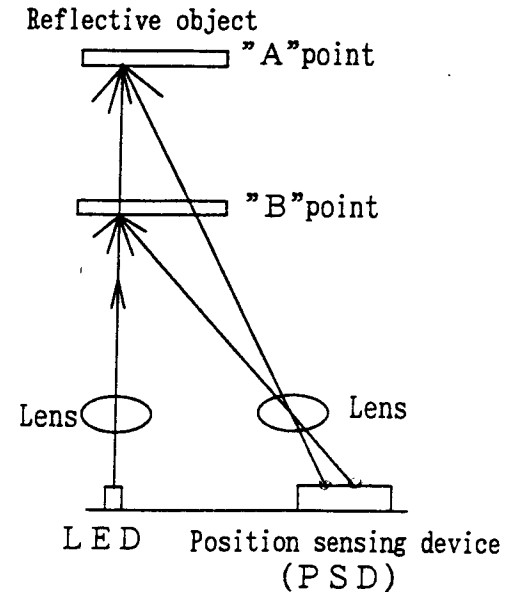

### 2-2. Features of the GP2D12/15

- ① Compact high performance distance measuring sensor with built-in PDS, Infrared LED and signal processing circuit
- ② No need to input signal, it can be handled easily.  
(Input signal is needed in case conventional GP2D12/15.)
- ③ Little influence by color and reflective ratio of the reflective object
- ④ High accuracy measuring by sequential position detection and mean processing data output

### GP2D12

- Output voltage depending on the reflective object distance can be got by analog voltage output.
- Shipping after correcting the output deviation of the distance by SHARP.

### GP2D15

- 1 bit (H/L) output type (the detecting threshold distance :  $24\text{cm} \pm 3\text{cm}$ )
- Shipping after adjusting the detecting threshold distance by SHARP.
- Adjusting the detecting threshold distance by customer's demand (adaptable for another model) is also possible.

## 3. Attended issues in use

### 3-1. Direction of the reflective object

In case that reflective object has boundary line which material or color etc. are excessively different, in order to decrease deviation of measuring distance, it shall be recommended to set the sensor that the direction of boundary line and the line between emitter center and detector center are in parallel.

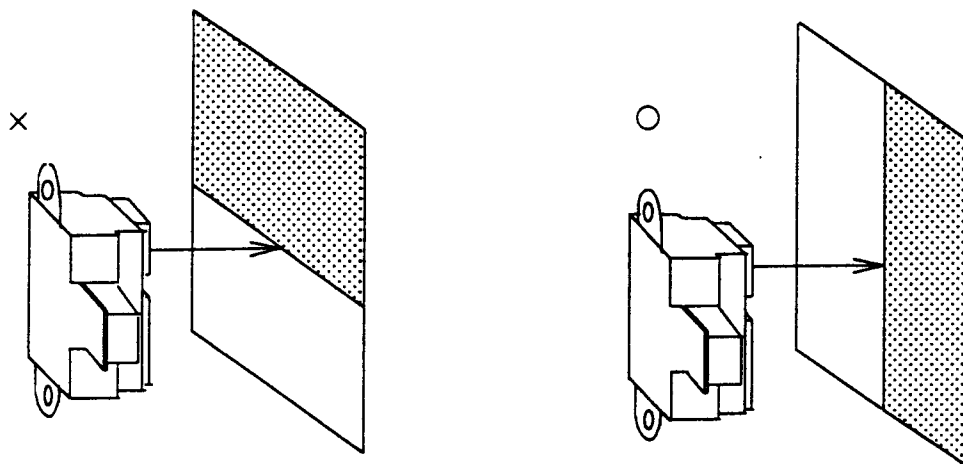

### 3-2. Moving direction of moving reflective object

In order to decrease deviation of measuring distance by moving direction of the reflective object, it shall be recommended to set the sensor that the moving direction of the object and the line between emitter center and detector center are vertical.

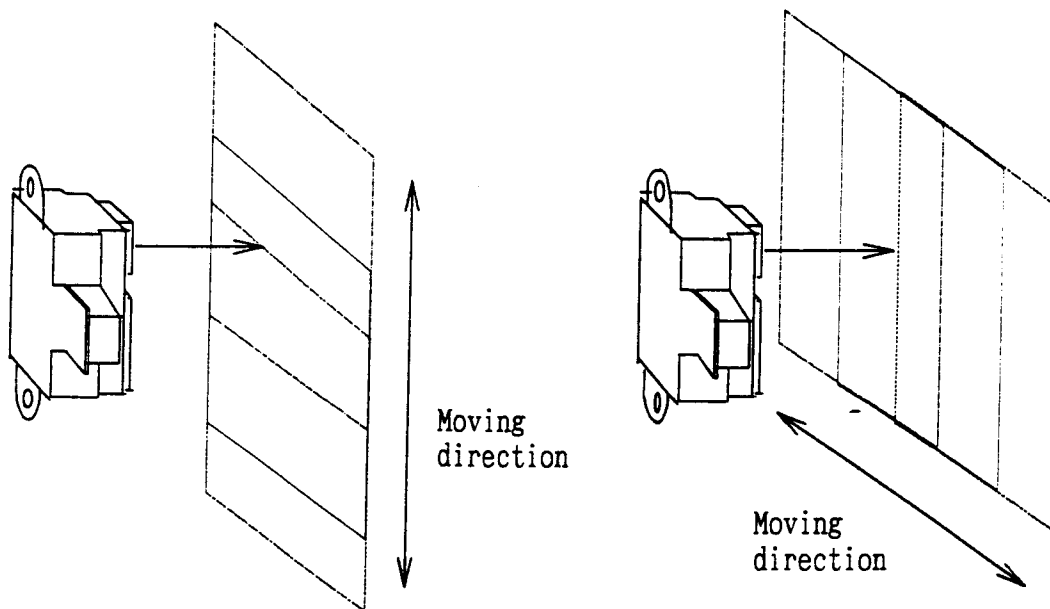

Detectable area vs. moving object example of characteristics are the next page.

The GP2D12 in the following figure, it dictates analog output voltage for each reflective object distance at the detectable area at  $X=0[\text{cm}]$ . The reflective object edge shows the change of analog output voltage when it moves from the lens center. For example, the detecting H/L threshold voltage at  $X=0[\text{cm}]$  shall be about 0.95V, if the detecting threshold distance shall be adjusted at  $L=30[\text{cm}]$ , then, the detectable area at the reflective object distance  $L=10[\text{cm}]$  have the range (about -1.1cm to +1.1cm) where the characteristics at  $L=10[\text{cm}]$  cross at the threshold voltage (about 0.95V).

Example of the detectable area characteristics of the GP2D12

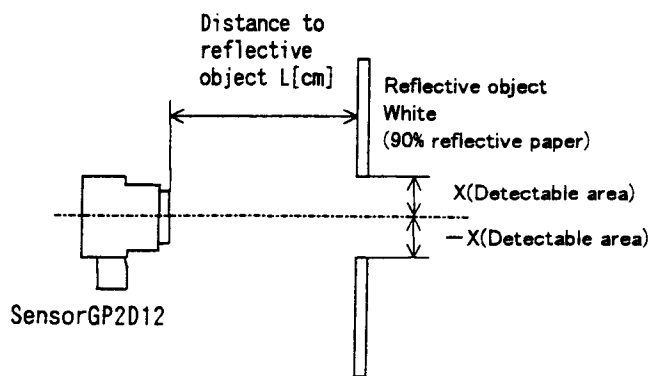
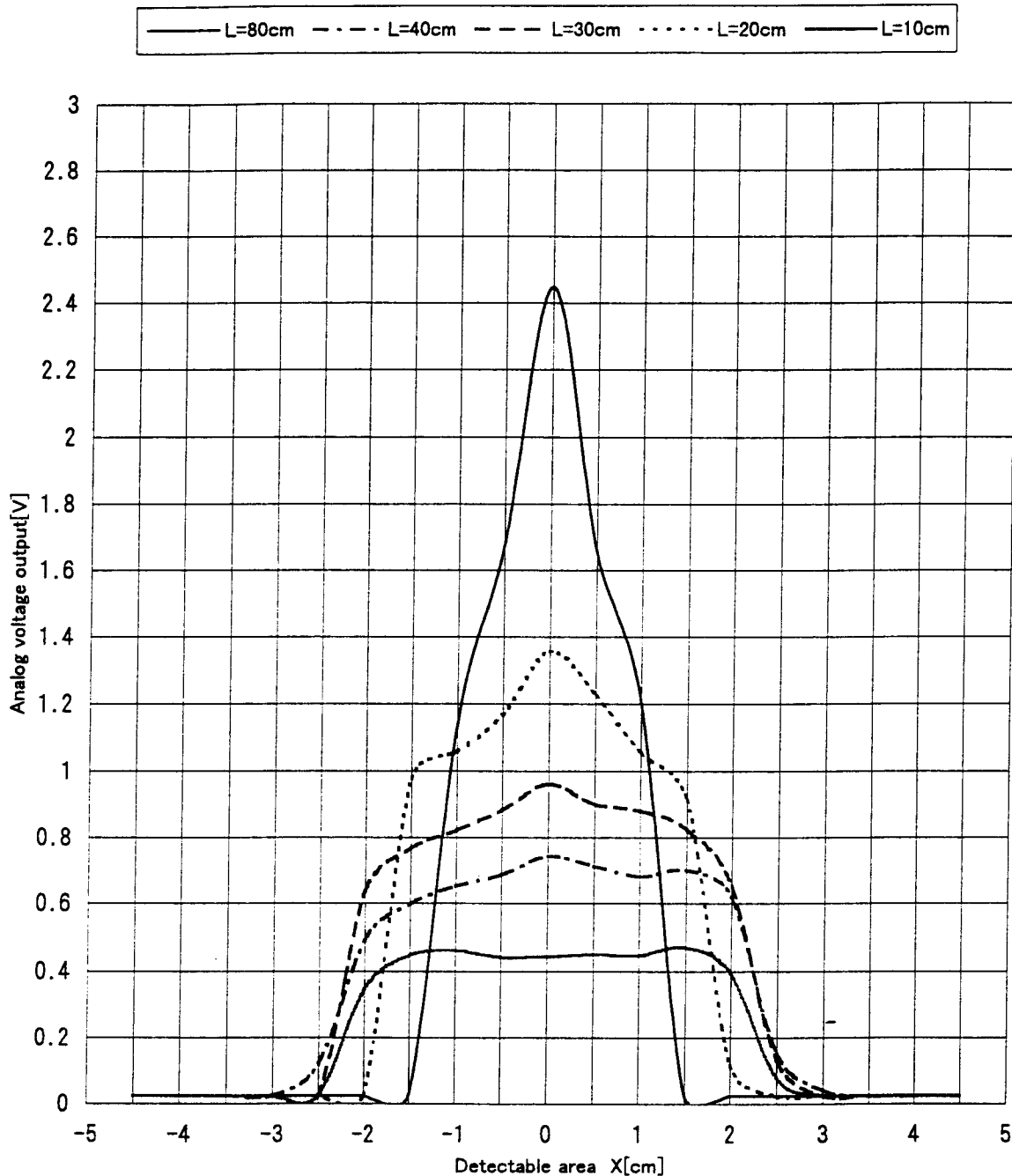

## 3-3. External disturbing light resistance characteristics

If the direct light from light source such as the sun, tungsten lamp etc. comes into the detector surface, there are cases that it can not measure exactly. Please consider the design that the direct light from such light source does not come into the detector surface.

External disturbing light resistance characteristics of the GP2D12 as example is shown in the following page.

## 3-4. Output at glittering reflective object

### 3-4-1. In case of glittering reflective object with no diffused reflective light ingredient (Mirror, Glass etc.)

LED light beam has an expanse. (Half intensity angle for LED in GP2D12/15 :  $\Delta \theta = 1.5^\circ$  ).

Therefore, in case that there is glittering reflective object at "A" point in the right drawing, the glittering reflected light comes into the detecting device from "B" point and it shall be the same output when there is the diffused lustrous reflective object at "C" point, so that accurate measuring is not possible.

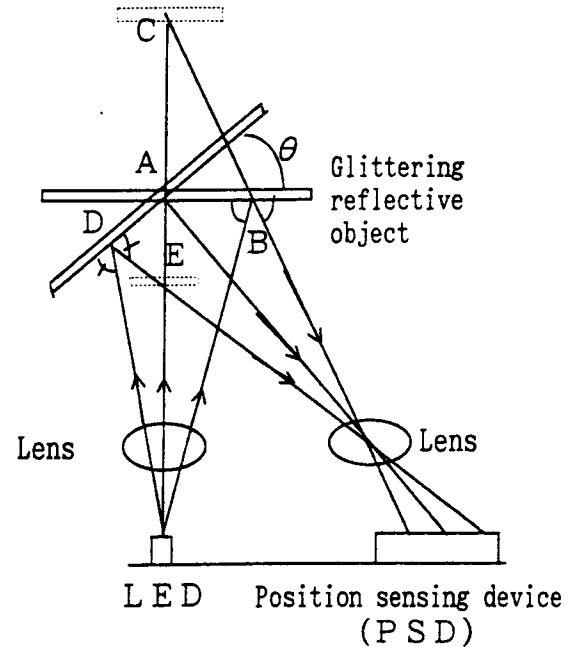

### 3-4-2. In case of lustrous reflective object with diffused reflective light ingredient (painted metal, Colored vinyl etc.)

In case that lustrous reflective object with diffused reflective light ingredient shall be measured, accurate measuring for the distance between the sensor and the object is possible by tilting the lustrous reflective object like the following drawing since the glittering reflective light ingredient runs away to "Y" direction and the diffused reflective light ingredient comes into the detecting device (PSD).

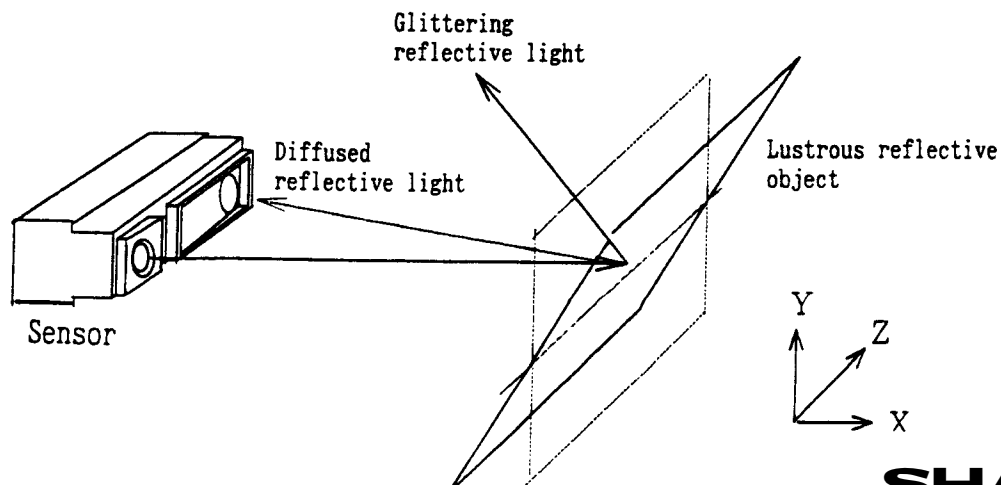

GP2D12 Illuminate characteristics

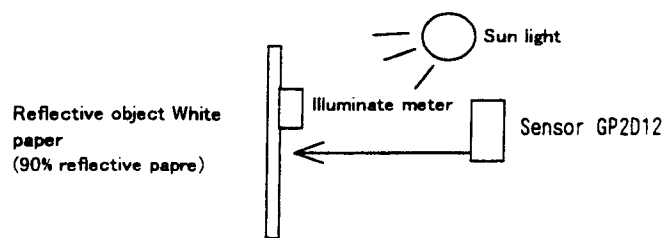
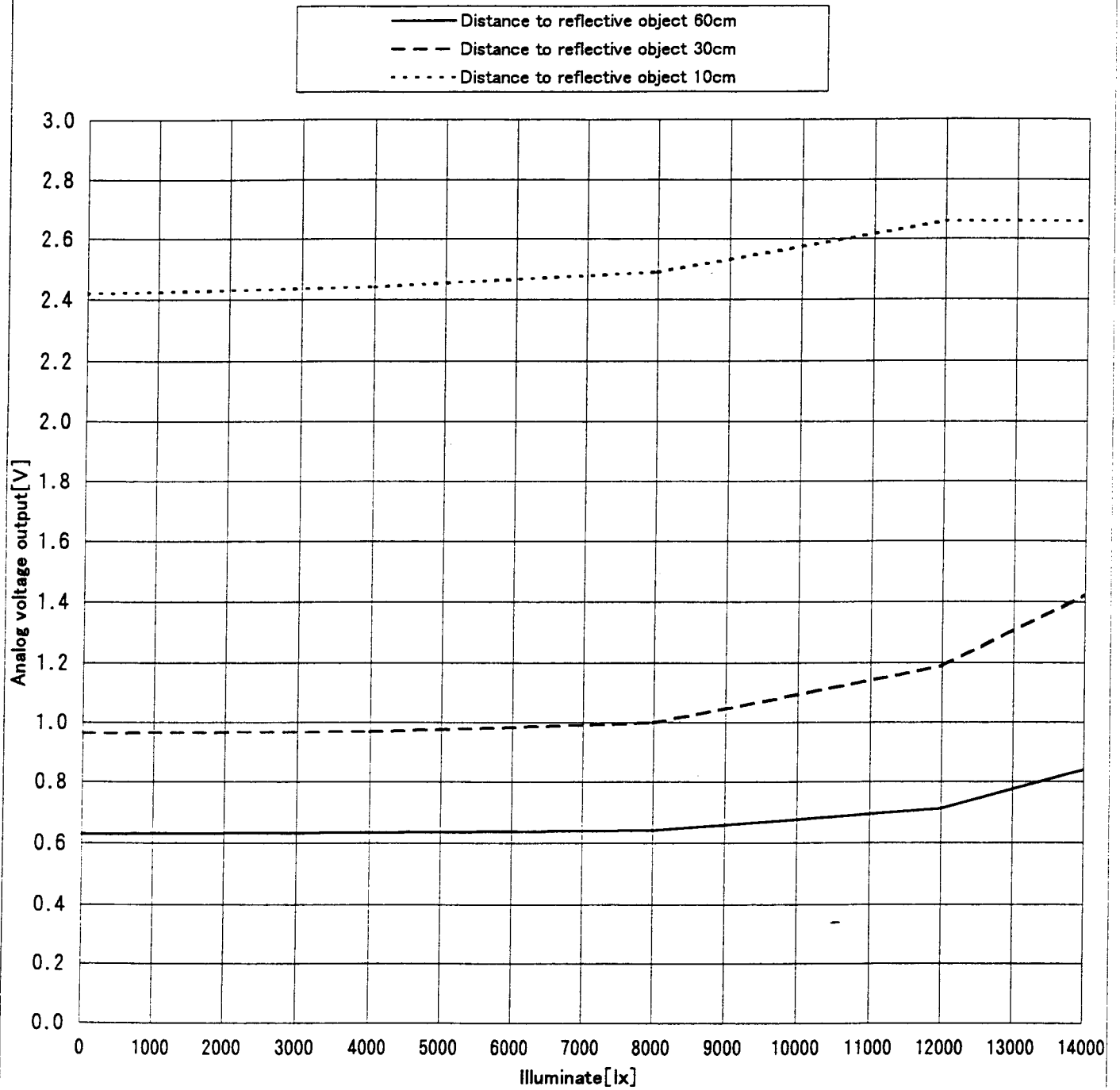

## 3-5. Ambient temperature

Example of ambient temperature characteristics of the GP2D12 as example is shown in the following page.

## 3-6. Optical conditions in front of the sensor

- ① Please consider that there is no object which interrupt the LED beam from sensor or no object which interrupt the reflective light from the reflective object to the detector portion.

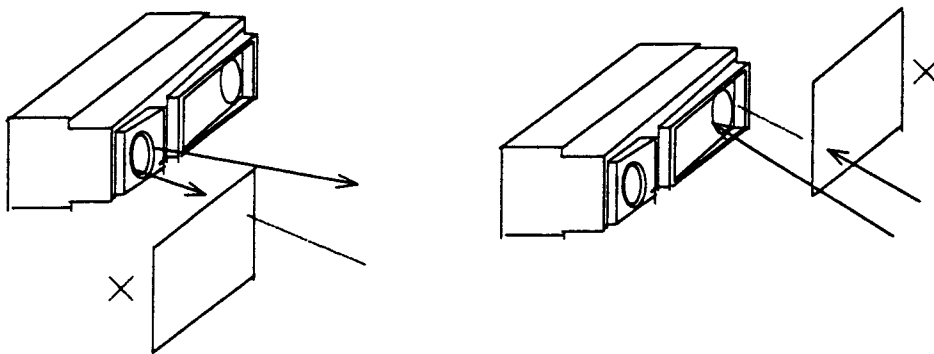

- ② In case that an optical filter is set in front of the sensor, the filter must have high transmittance with emitted spectrum wavelength of LED ( $\lambda = 850\text{nm} \pm 70\text{nm}$ ) which is used in the sensor, please use the filter whose surface is face and back mirror.  
(When there's like sand brushing on the surface, there is a case that the light is diffused inside of the filter, so the filter is sometimes detected.)

Also, the clearance between the sensor and the optical filter should be set at 1 mm or less. In case that the clearance is 1 mm or more, in order to avoid the light emitting from the filter to the detector, which is emitted from LED and is glittering reflected by the filter, the following would be recommended.

- a) Set a tube to the filter on emitter side.
- b) Set a shading board between emitter lens and detector lens.

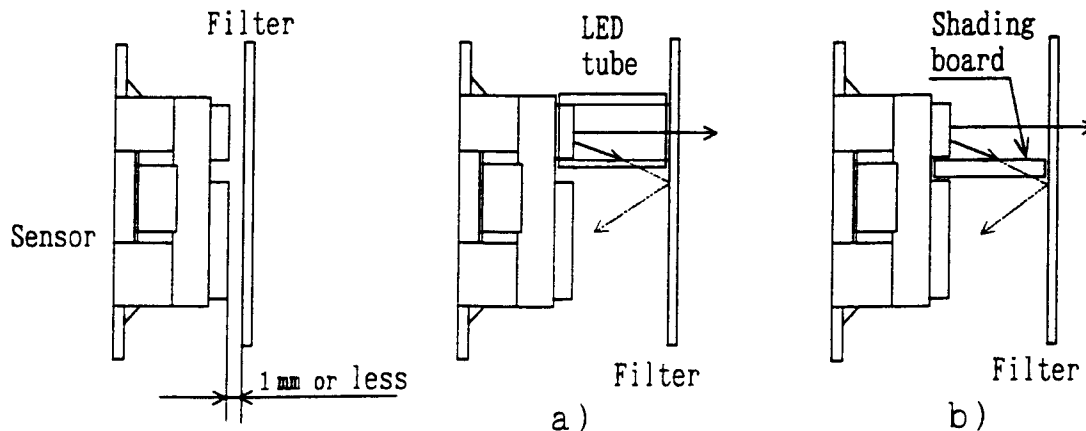

When an optical filter is used, please use it after confirming the operation in actual application.

Example of the temperature characteristics of the GP2D12

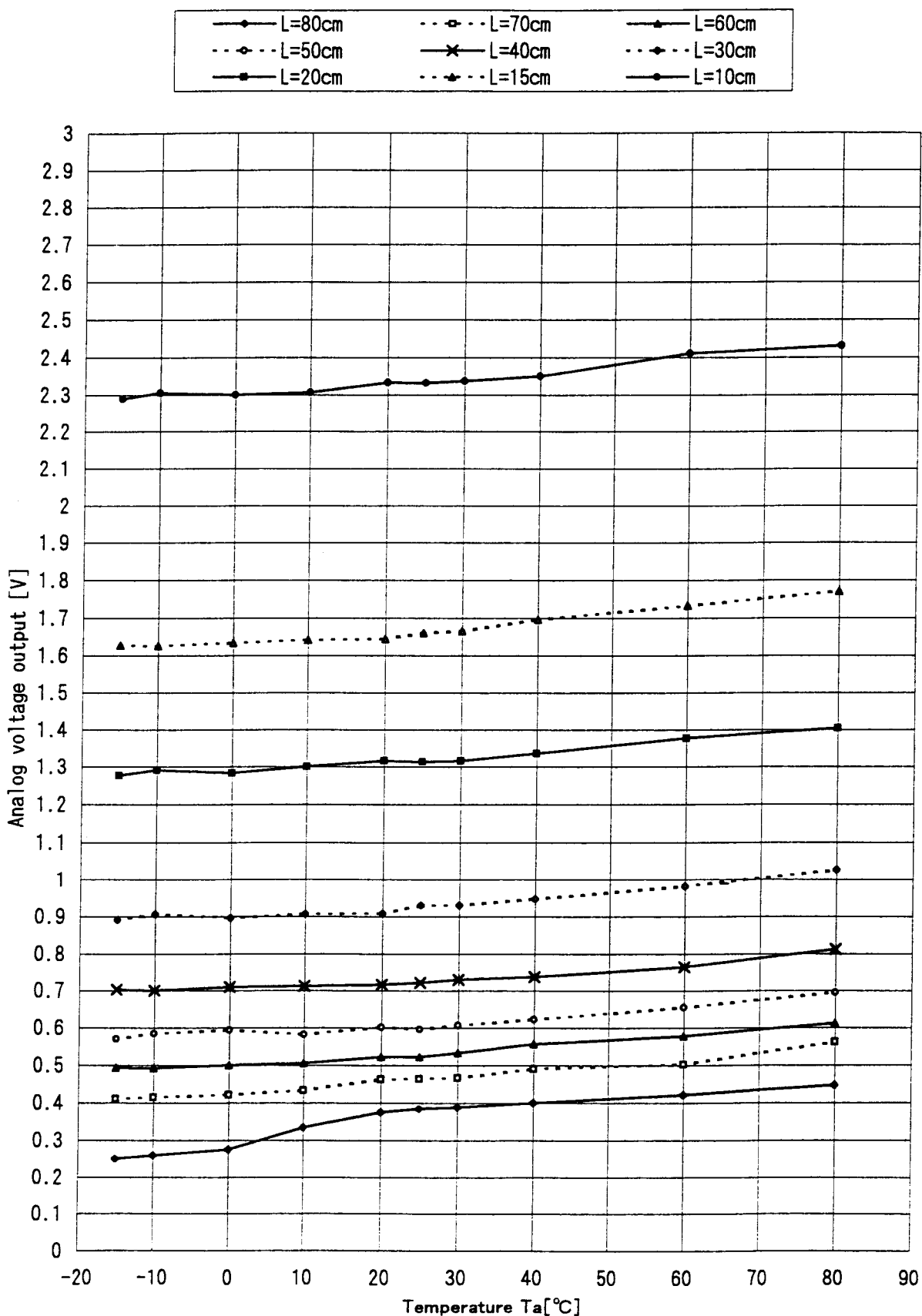



## 4. Characteristics of GP2D12/15

### 4-1. Characteristics of GP2D12

GP2D12 is an analog voltage output type distance measuring sensor and detects the analog voltage depends on the distance from the reflective object.

Output voltage vs. distance and vs. reciprocal of distance examples of characteristics are the following.

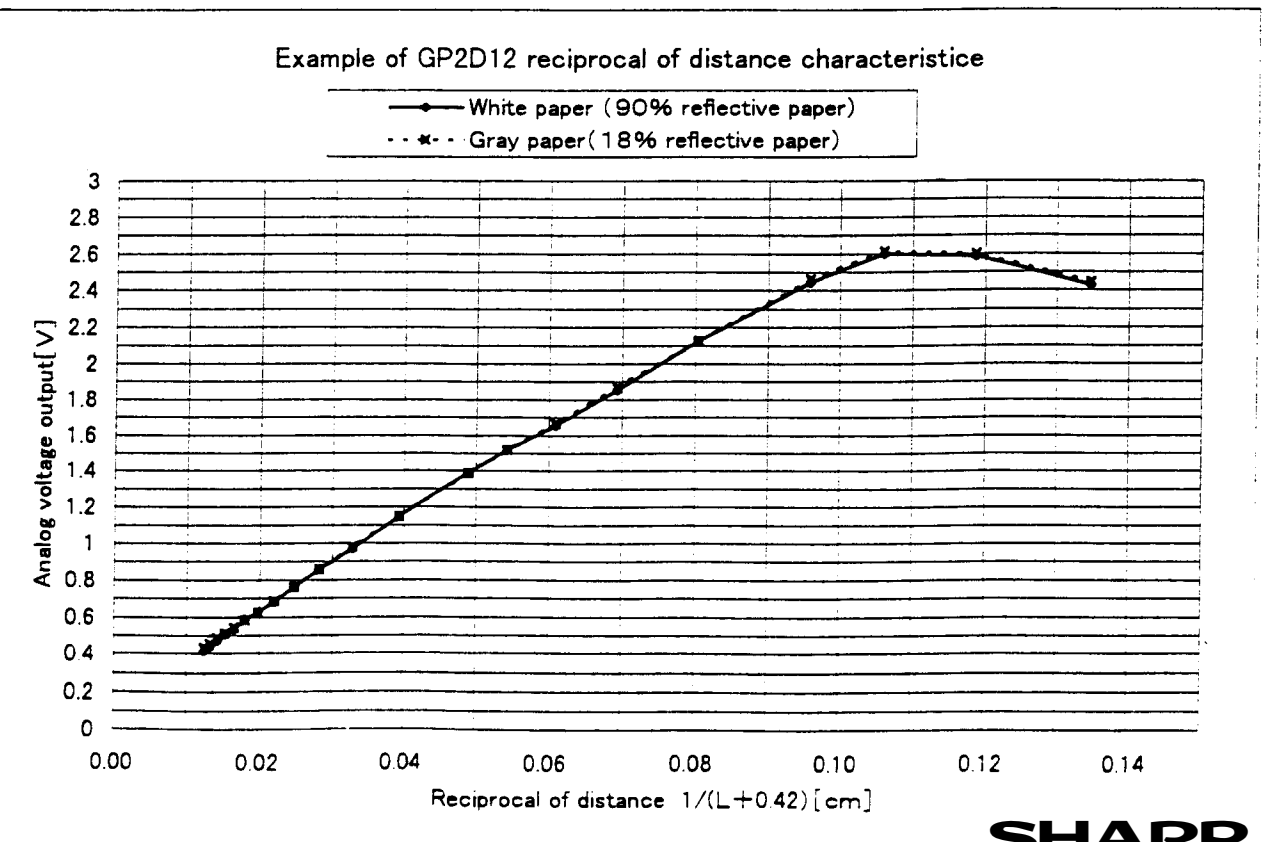
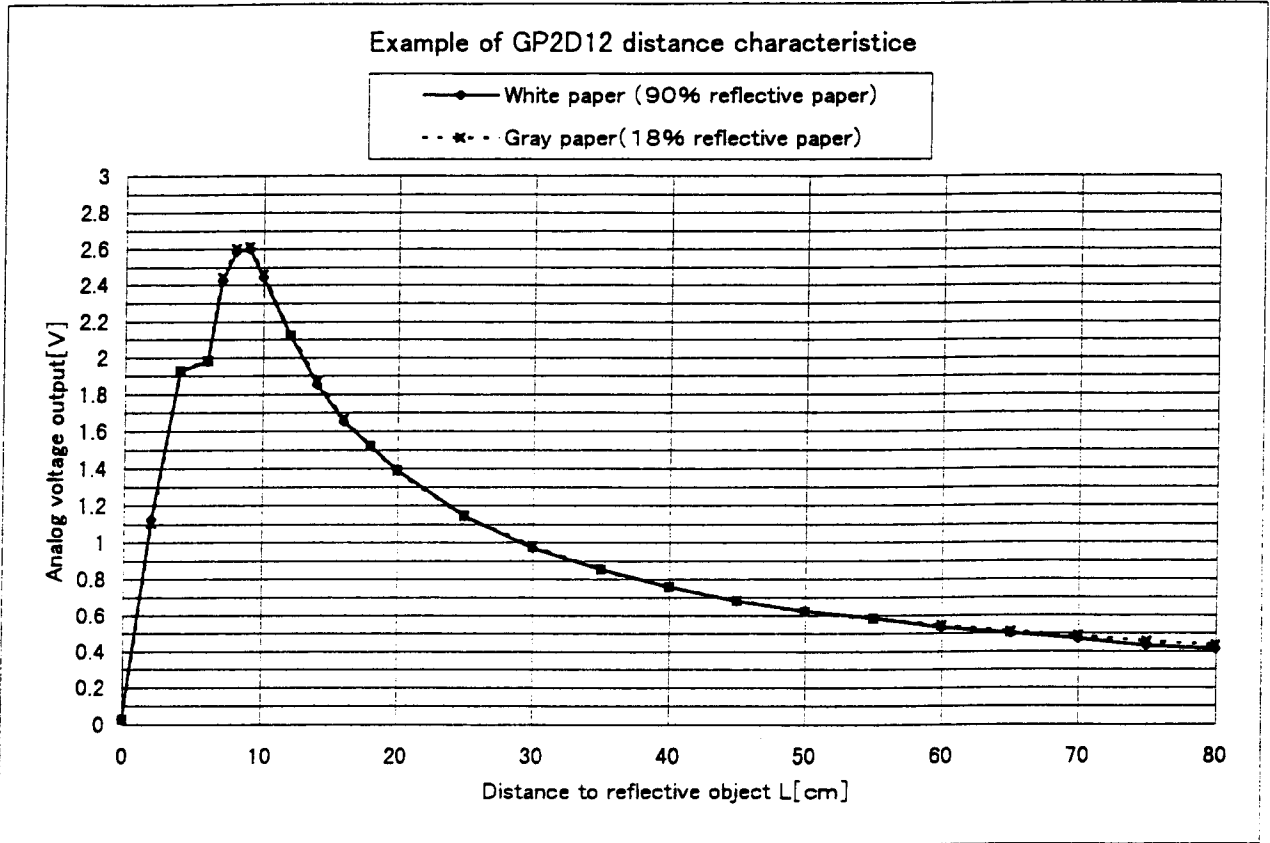

4-2. Characteristics of GP2D15

GP2D15 is 1 bit (H/L) output performance type distance measuring sensor, and it's able to detect the reflective object at the set-up detection distance ( $L=24 \pm 3\text{cm}$ ).

Also, this GP2D15 type has a hysteresis width at the detection distance and has no area, where the output is unstable like the distance measuring sensor currently in use. Therefore, the stable output of H or L is acquired.

Example of output distance characteristics are the following.

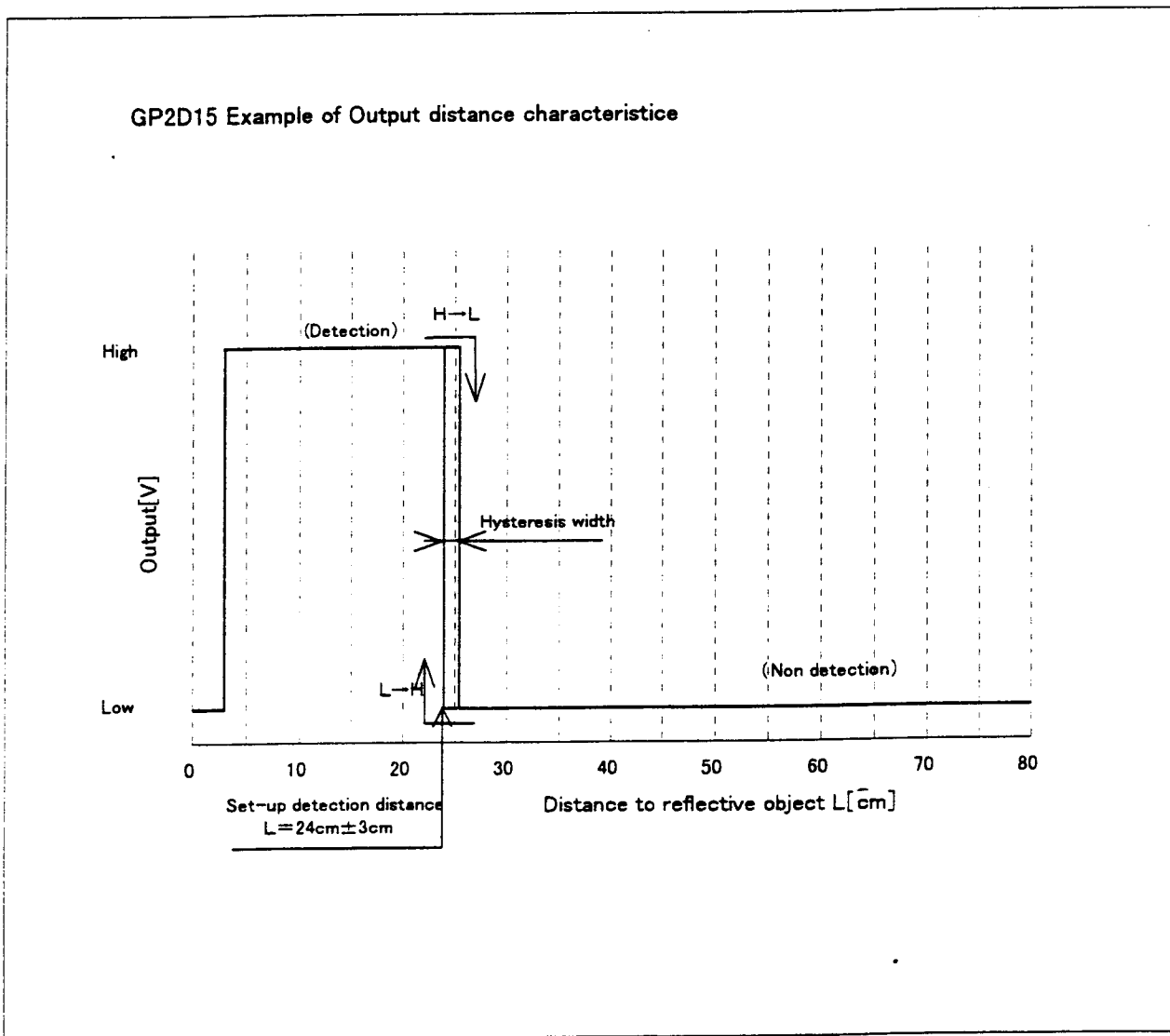

5. Supplement

Modification of the measuring range

The following expression shall be realized by geometrical relation among the distance to the reflective object : "L", Base line length : "A", Focal distance of the lens : "f" and Optical spot position on PSD : "X".

$$X = (A \times f) / L$$

For example, when possible measuring range would like to be changed without any change of PSD detector size, it can be realized by changing the base line length : "A" or the focal distance of the lens : "f". Current distance measuring sensors

The lineup of distance measuring sensor shall be the following

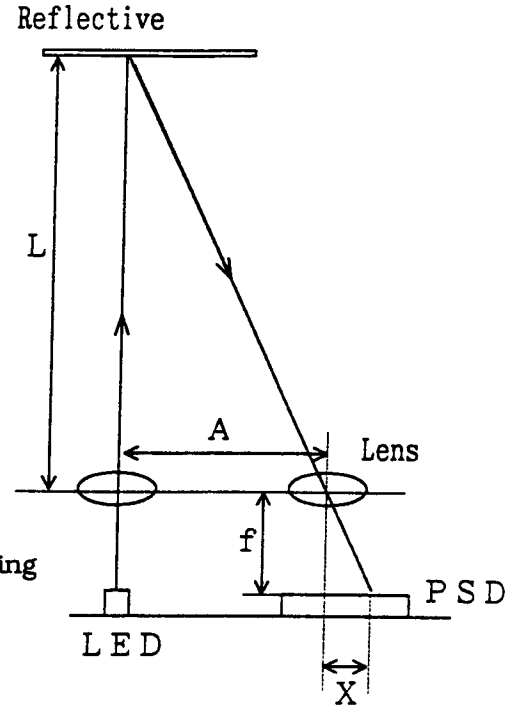

5-2. The lineup of distance measuring sensor

Analog voltage output type

GP2D12

Measuring range : 10cm to 80cm

1 bit (H/L) Output type

GP2D15

Detecting threshold distance : 24cm ± 3cm

Measuring range : 10cm to 80cm

GP2D150A

Detecting threshold distance : 15cm ± 2.5cm

Measuring range : 3cm to 30cm

**SPECIFICATIONS ARE SUBJECT TO CHANGE WITHOUT NOTICE.**

Suggested applications (if any) are for standard use; See Important Restrictions for limitations on special applications. See Limited Warranty for SHARP's product warranty. The Limited Warranty is in lieu, and exclusive of, all other warranties, express or implied. ALL EXPRESS AND IMPLIED WARRANTIES, INCLUDING THE WARRANTIES OF MERCHANTABILITY, FITNESS FOR USE AND FITNESS FOR A PARTICULAR PURPOSE, ARE SPECIFICALLY EXCLUDED. In no event will SHARP be liable, or in any way responsible, for any incidental or consequential economic or property damage.

---

# SHARP®

## **NORTH AMERICA**

---

SHARP Microelectronics of the Americas  
5700 NW Pacific Rim Blvd.  
Camas, WA 98607, U.S.A.  
Phone: (1) 360-834-2500  
Fax: (1) 360-834-8903  
Fast Info: (1) 800-833-9437  
www.sharpsma.com

## **EUROPE**

---

SHARP Microelectronics Europe  
Division of Sharp Electronics (Europe) GmbH  
Sonninstrasse 3  
20097 Hamburg, Germany  
Phone: (49) 40-2376-2286  
Fax: (49) 40-2376-2232  
www.sharpsme.com

## **JAPAN**

---

SHARP Corporation  
Electronic Components & Devices  
22-22 Nagaike-cho, Abeno-Ku  
Osaka 545-8522, Japan  
Phone: (81) 6-6621-1221  
Fax: (81) 6117-725300/6117-725301  
www.sharp-world.com

## **TAIWAN**

---

SHARP Electronic Components  
(Taiwan) Corporation  
8F-A, No. 16, Sec. 4, Nanking E. Rd.  
Taipei, Taiwan, Republic of China  
Phone: (886) 2-2577-7341  
Fax: (886) 2-2577-7326/2-2577-7328

## **SINGAPORE**

---

SHARP Electronics (Singapore) PTE., Ltd.  
438A, Alexandra Road, #05-01/02  
Alexandra Technopark,  
Singapore 119967  
Phone: (65) 271-3566  
Fax: (65) 271-3855

## **KOREA**

---

SHARP Electronic Components  
(Korea) Corporation  
RM 501 Geosung B/D, 541  
Dohwa-dong, Mapo-ku  
Seoul 121-701, Korea  
Phone: (82) 2-711-5813 ~ 8  
Fax: (82) 2-711-5819

## **CHINA**

---

SHARP Microelectronics of China  
(Shanghai) Co., Ltd.  
28 Xin Jin Qiao Road King Tower 16F  
Pudong Shanghai, 201206 P.R. China  
Phone: (86) 21-5854-7710/21-5834-6056  
Fax: (86) 21-5854-4340/21-5834-6057

### **Head Office:**

No. 360, Bashen Road,  
Xin Development Bldg. 22  
Waigaoqiao Free Trade Zone Shanghai  
200131 P.R. China  
Email: smc@china.global.sharp.co.jp

## **HONG KONG**

---

SHARP-ROXY (Hong Kong) Ltd.  
3rd Business Division,  
17/F, Admiralty Centre, Tower 1  
18 Harcourt Road, Hong Kong  
Phone: (852) 28229311  
Fax: (852) 28660779  
www.sharp.com.hk

### **Shenzhen Representative Office:**

Room 13B1, Tower C,  
Electronics Science & Technology Building  
Shen Nan Zhong Road  
Shenzhen, P.R. China  
Phone: (86) 755-3273731  
Fax: (86) 755-3273735